

Limited Liability Company
" Inzhkomsentr VVD "
(ООО "Инжкомцентр ВВД")

**Electric heating device
for baths and saunas EHD
"Premiera Profi"**

Electric power: 24; 36; 42; 48; 54; 63; 72 kW

Instruction Manual

ATTENTION!!!

Before you start installing and operating "Premiera Profi" electric heating device, carefully read this Instruction Manual. It is strictly forbidden to leave the working electric heating device "Premiera Profi" without supervision. To avoid fire, it is forbidden to cover "Premiera Profi" electric heating device with any objects or materials.

This Instruction Manual is a document that provides information about the design, characteristics and instructions for the correct and safe operation, maintenance, transport and storage of the product.

Due to the constant improvement of the design and manufacturing technology of products, in this Instruction Manual there may be some discrepancies between the description and the product, which do not affect its performance and do not worsen its technical characteristics.

CONTENT

1. Description and operation	3
1.1 Purpose of the product	3
1.2 Technical specifications	3
1.3 Product structure.....	6
1.4 Production construction and operation.....	16
1.5 Control-measuring instrumentation	17
1.6 Marking and sealing	17
1.7 Packaging.....	18
2. Product usage.....	18
2.1 Preparing the room before using the product	18
2.2 Safety measures.....	18
2.3 Preparing the device for use.....	20
2.4 Device operation.....	20
2.5 Work procedure.....	21
2.6 Possible malfunctions and their elimination.....	22
2.7 Operations in extreme conditions.....	22
3. Technical maintenance	22
4. Storage and transportation.....	23
5. Utilization	23
6. Warranty obligations	23
Annex 1.....	24
Annex 2	26
Annex 3	29
Diagrams of possible maximum configurations of stoves.....	30
Warranty card.....	32

1. Description and operation

1.1 Product purpose

The electric heating device for baths and saunas END "Premiera - Profi" (hereinafter referred to as - the Device, EHD) is designed to create and maintain the necessary temperature and humidity conditions in the steam room.

1.2 Technical specifications of the device

The appearance of the device is shown in Figures 1.2.1; 1.2.2; 1.2.3

Table 1.2.1

Name	Measure unit	Norms, parameters						
		24 (1x24)	36 (2x18)	42 (2x21)	48 (2x24)	54 (3x18)	63 (3x21)	72 (3x24)
Rated power consumption *	kW	24 (1x24)	36 (2x18)	42 (2x21)	48 (2x24)	54 (3x18)	63 (3x21)	72 (3x24)
Number of sections (blocks) for installation of tubular heating elements	pc	1	2			3		
Recommended rated current of the circuit breaker	A	50	80 or 2x40	100 or 2x50	125 or 3x40	125 or 3x50		
Cross-section of power and grounding wires from the input and distribution board to the power unit of the control panel	mm ²	5x25	5x16		5x25	5x25		5x35
Cross-section of power and grounding wires from the power unit of the control panel to the furnace	mm ²	5x10	2x (5x6)		2x (5x10)	3x (5x6)		3x (5x10)
Recommended room size (from-to)	m ³	20-30	40-55	55-70	70-80	80-100	100-130	130-180
Supply voltage	V	380						
Dimensions (D x W x H)	mm	795 x 795 x 1075	1100 x 795 x 1075			1600 x 795 x 1075		
Stove weight without lining	kg	90	180			270		
Weight of stone cladding **	kg	200	300			390		
Weight of "Himalayan salt" cladding**	kg	180	270			360		
Recommended weight of stones for vaporization ***	kg	300	400			500		
Weight of the heat accumulator (1 pc)****	kg	53						
Air cone weight (1 pc)****	Large	kg						
	Small	kg						
Current type		variable						
Operation mode		continuous						
Electric shock protection class		1						
Moisture protection design		IPX4						
Installation method design		outdoor						

Notes:

* The specified power is sufficient to heat the room of the corresponding volume, provided that it is effectively thermally insulated and the supply voltage is not lower than the rated one. If necessary, the power can be reduced by synchronous shutdown of tubular electric heaters in the furnace blocks;

** When cladding on 4 sides;

*** A special compartment of the Device is filled with stones (jade, jadeite, soapstone) or cast iron kernels of the buyer's choice (purchased separately). The size of the stones should not be less than 120-150 mm. The diameter of the kernels should not be less than 120 mm. In the case of the installation of heat accumulators or air diffusers, the weight of the stones to be laid is reduced at the rate of about 15 kg per one installed heat accumulator or a large air diffuser, or three small air diffusers;

**** Sold separately

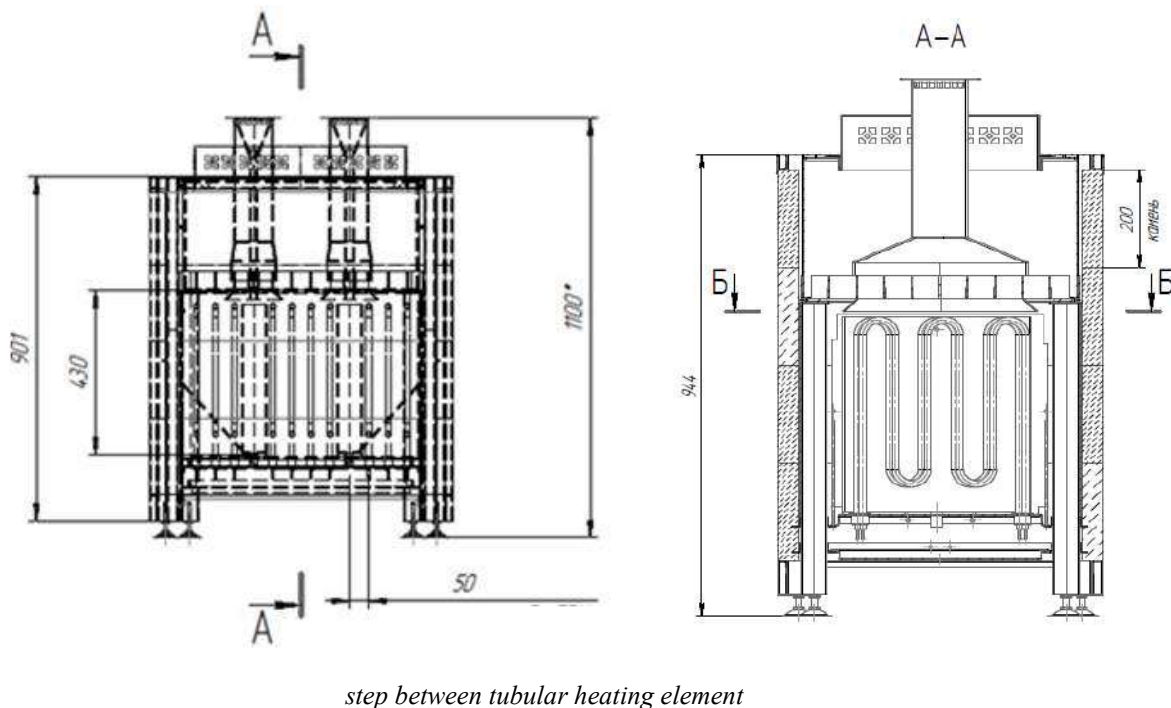

Fig. 1.2.1 Appearance of the device in a single-section version

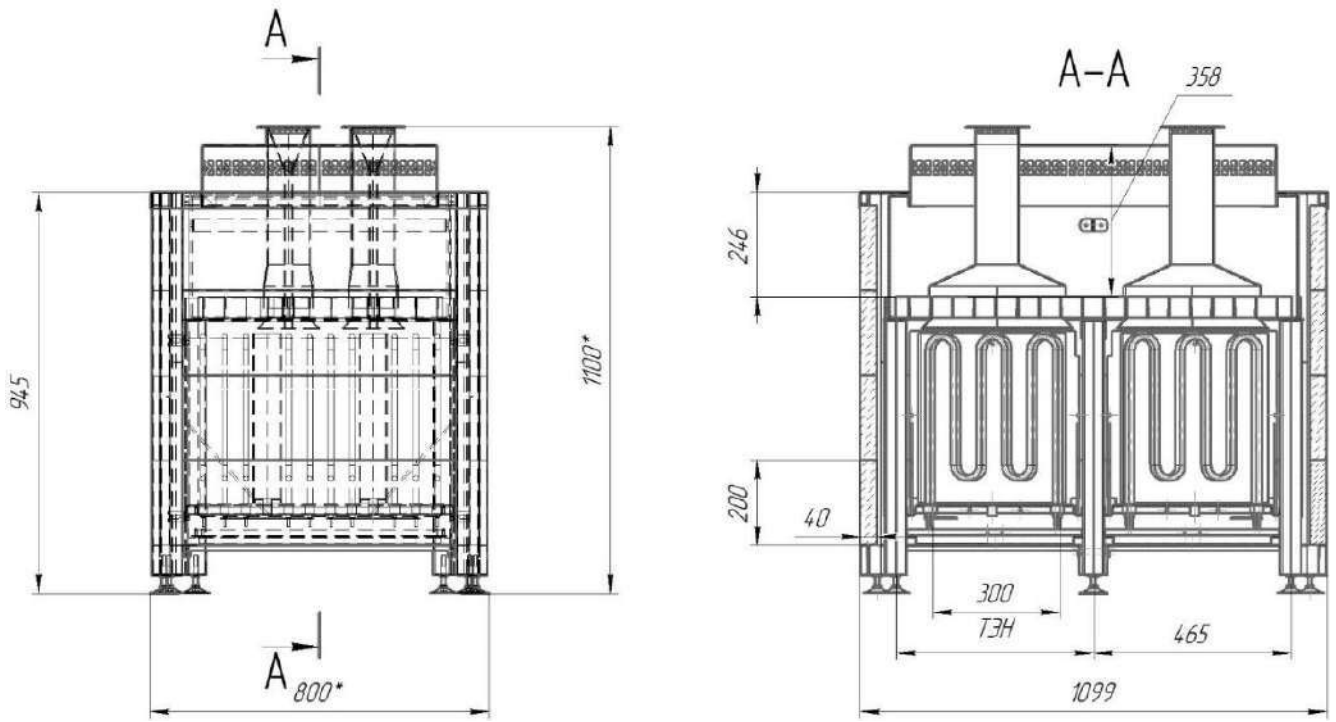
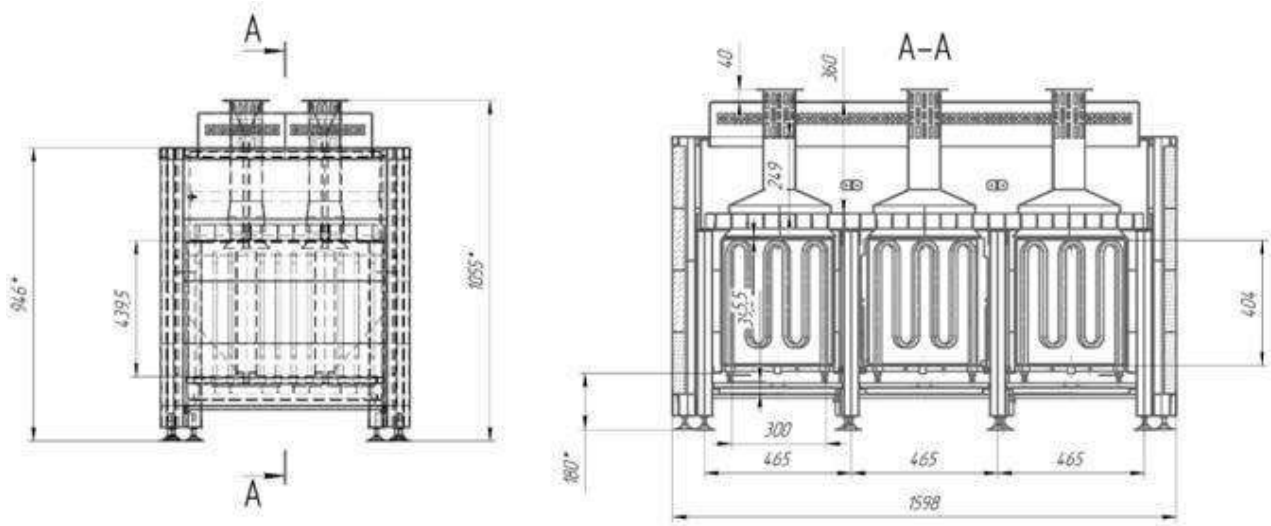

Fig. 1.2.1 Appearance of the device in a two-section version



* reference dimensions

Fig. 1.2.3 Appearance of the device in a three-section version

1.3 Product structure

##	Name	Measure unit	Количество
1	EHD "Premiera-Profi"	pc	1
2	Heat accumulator*	pc	1 to 6
3	Small air diffuser*	pc	1 to 18
4	Large air diffuser *	pc	1 to 6
5	Control console*	pc	1
6	Instruction Manual	pc	1
7	Packaging containers	pc	1 or 2

Notes:

* Sold separately

The control panel of the PU-02M model is equipped with a temperature sensor located outside the control unit and installed inside the steam room. The temperature sensor is connected to the control unit of its own 5/10 meter cable.

The electrical diagram of the electric heating device and the control panel is shown in Fig. 1.3.1; 1.3.2; 1.3.3; 1.3.4; 1.3.5*

* The recommended rated current of the circuit breaker, the type and cross-section of the wires used for connection are selected according to Table 1. 1.2.1 and 2.1.1.11 of this Instruction Manual

Number of tubular heating elements is given per a module.
 The modules in the same furnace are identical in terms of the set of
 tubular heating elements.

18 kW 36 kW 54 kW
 1 module 2 modules 3 modules

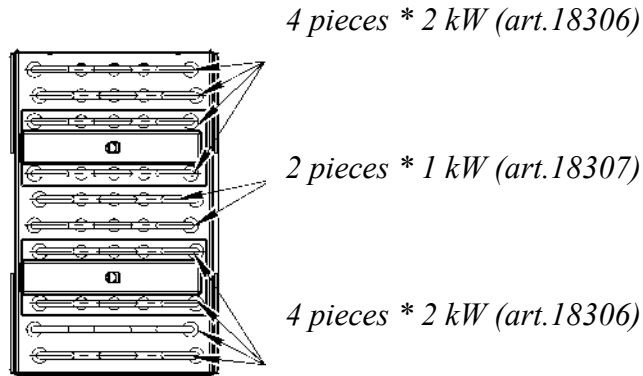

21 kW 42 kW 53 kW
 1 module 2 modules 3 modules

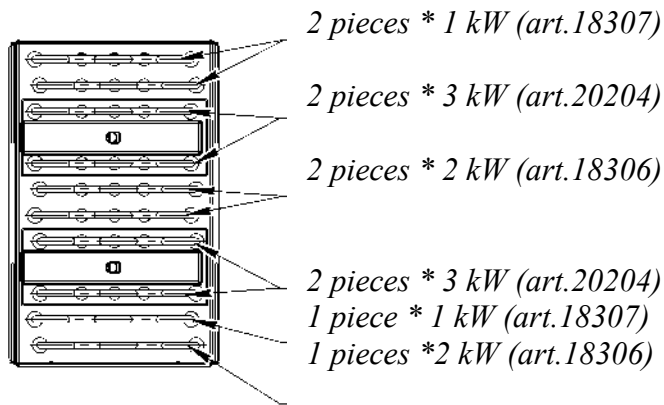

24 kW 48 kW 72 kW
 1 module 2 modules 3 modules

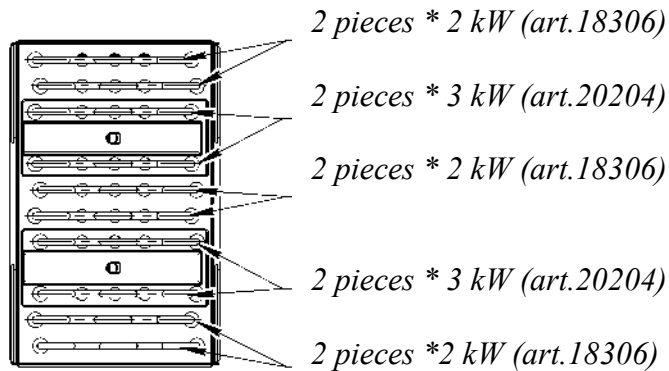

Rice. 1.3 Distribution of tubular electric heaters by number and power of 24-72 kW

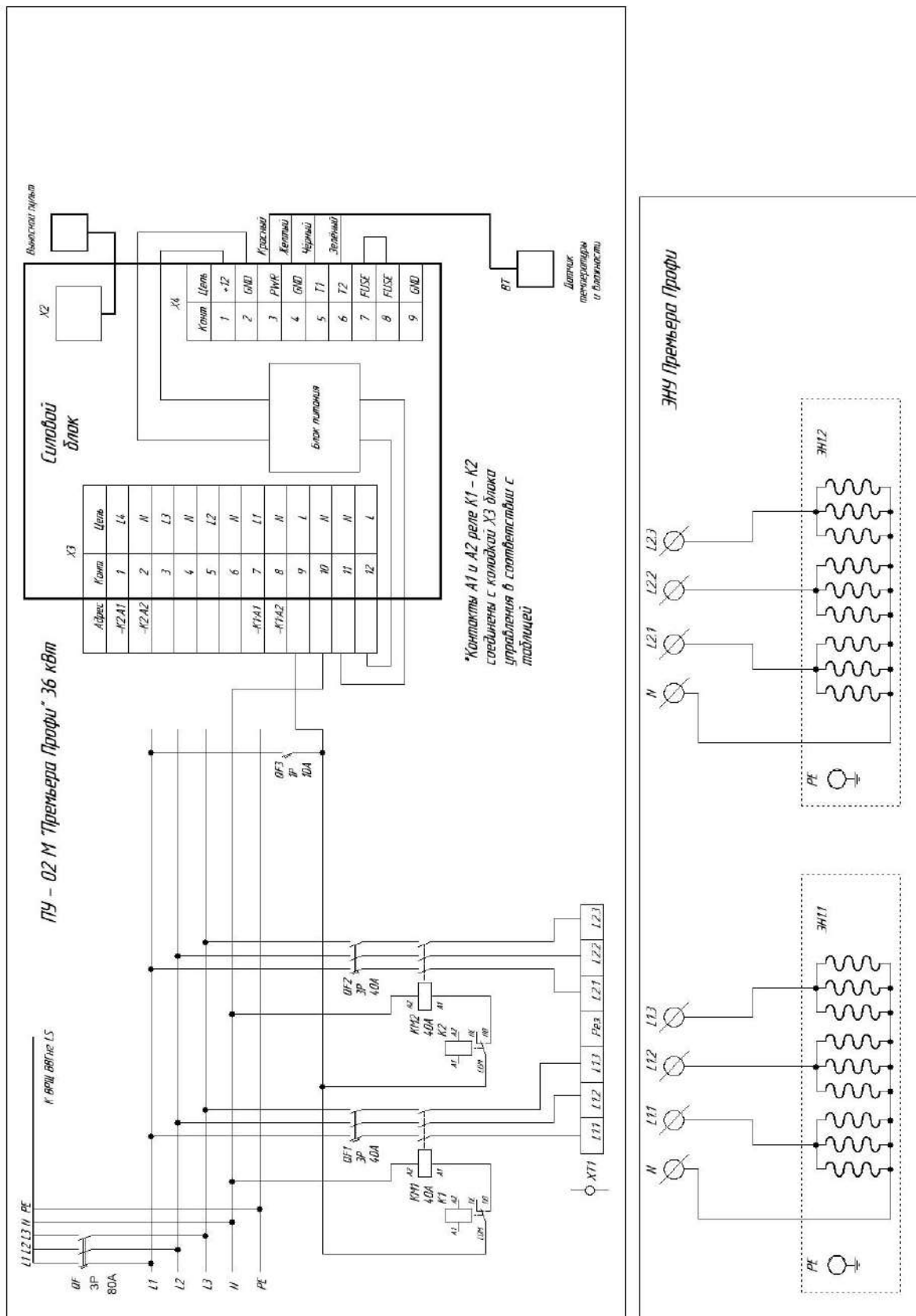

Fig. 1.3.2 Connection of the Device to the electrical network in a two-section version of 36 kW

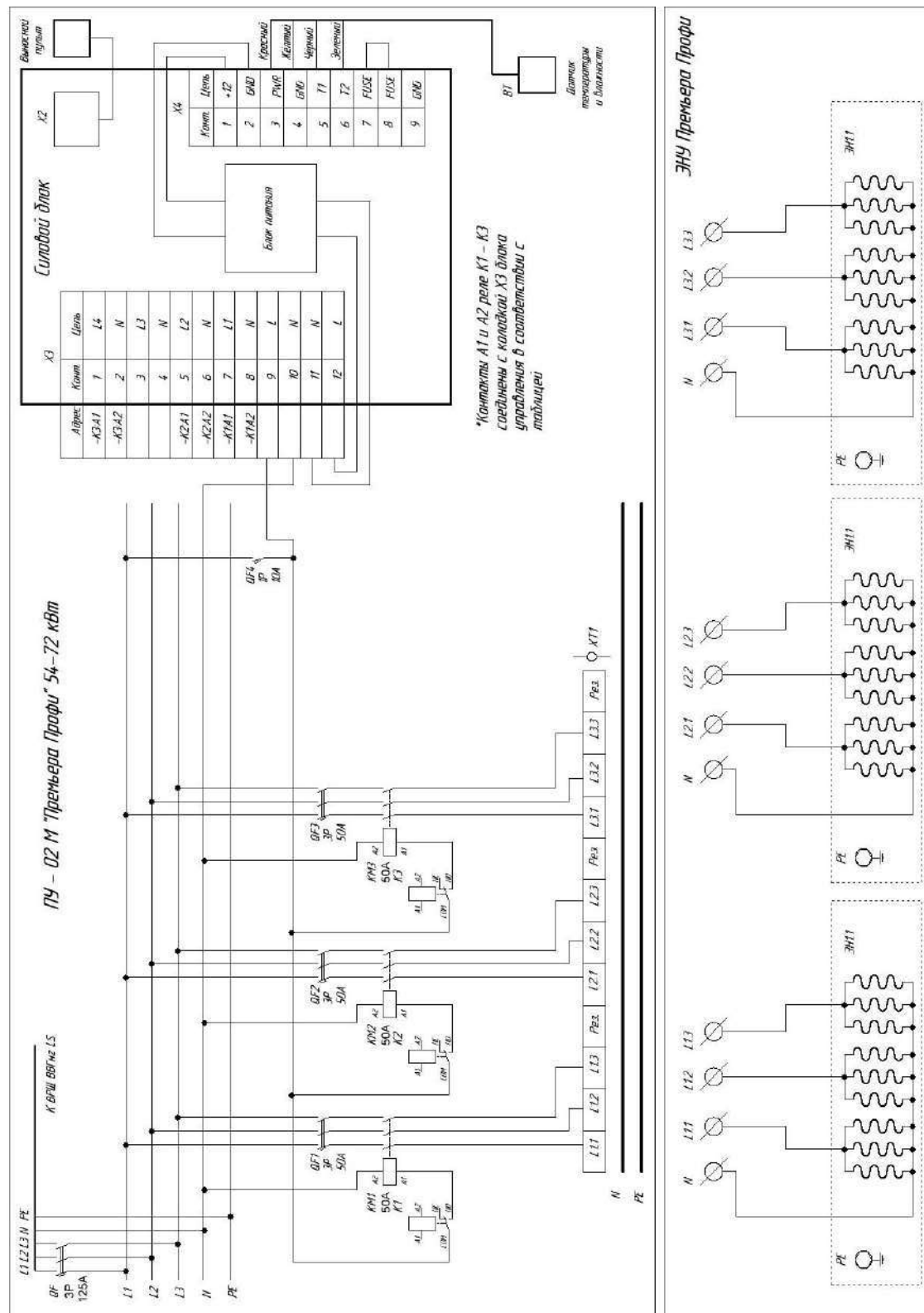

Fig. 1.3.4 Connection of the Device to the electrical network in a three-section version of 54 - 72 kW

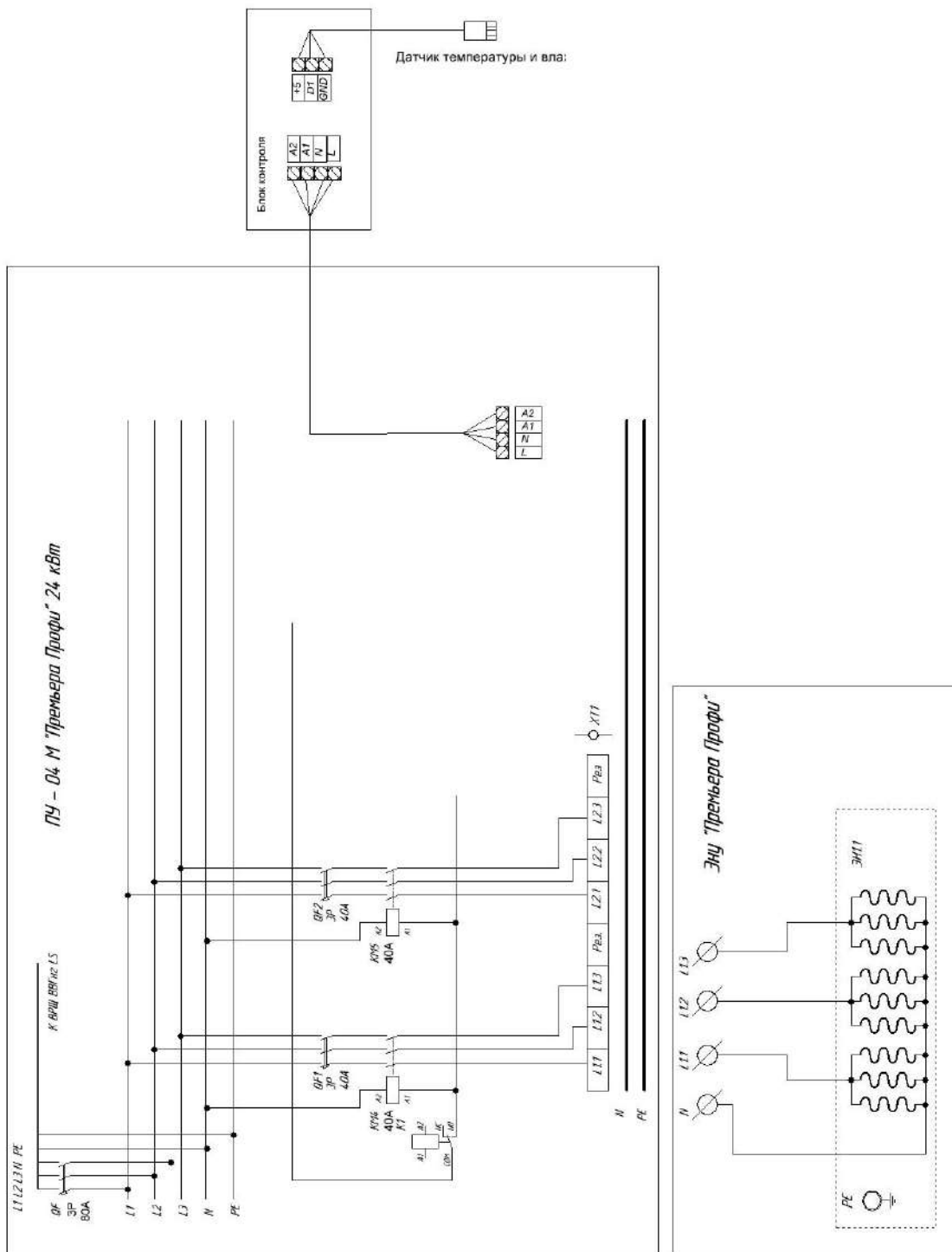

Fig. 1.3.5 Connection of the Device to the electrical network in the case of a single-section version of 24 kW

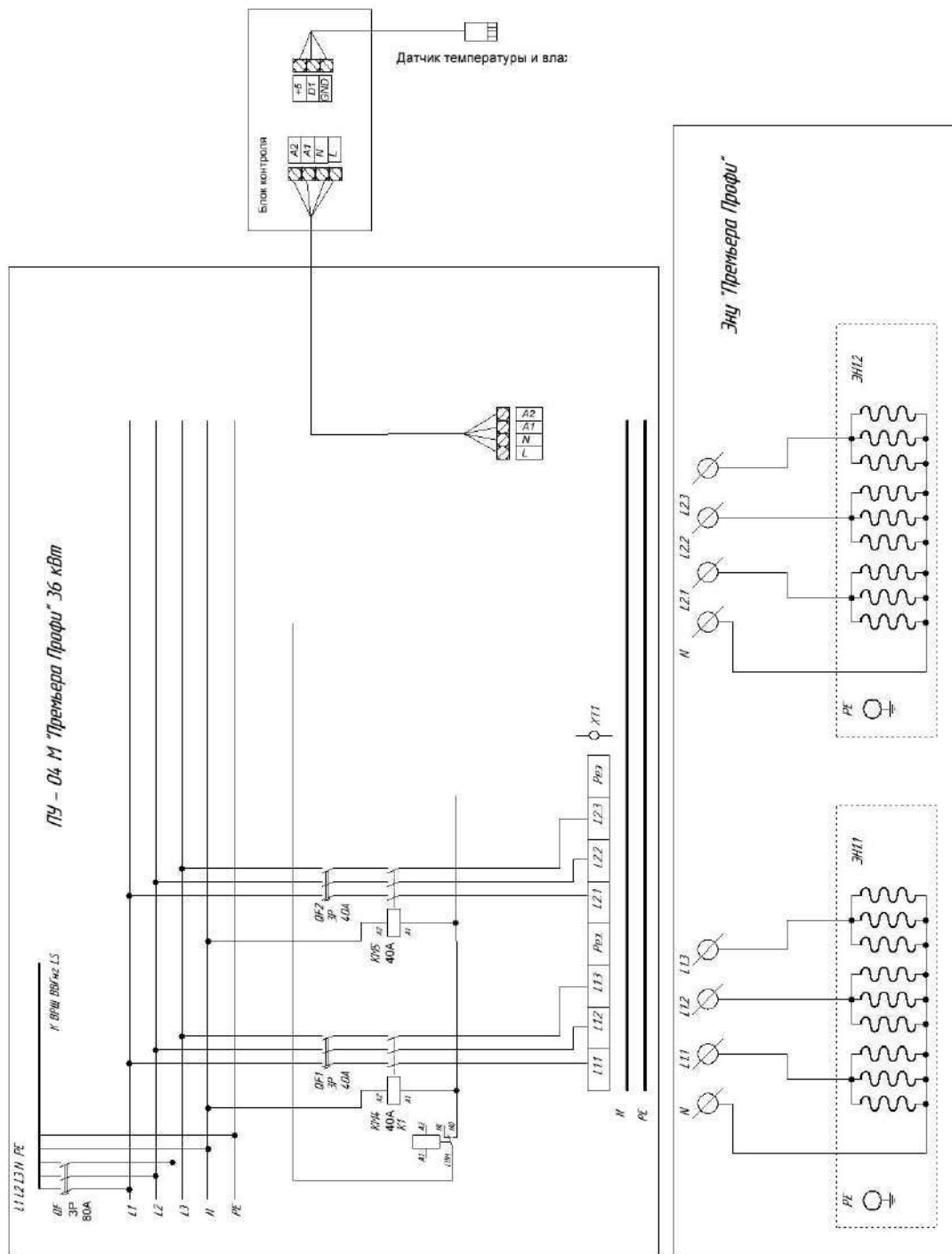

Fig. 1.3.6 Connection of the Device to the electrical network in the case of a single-section version of 36 kW

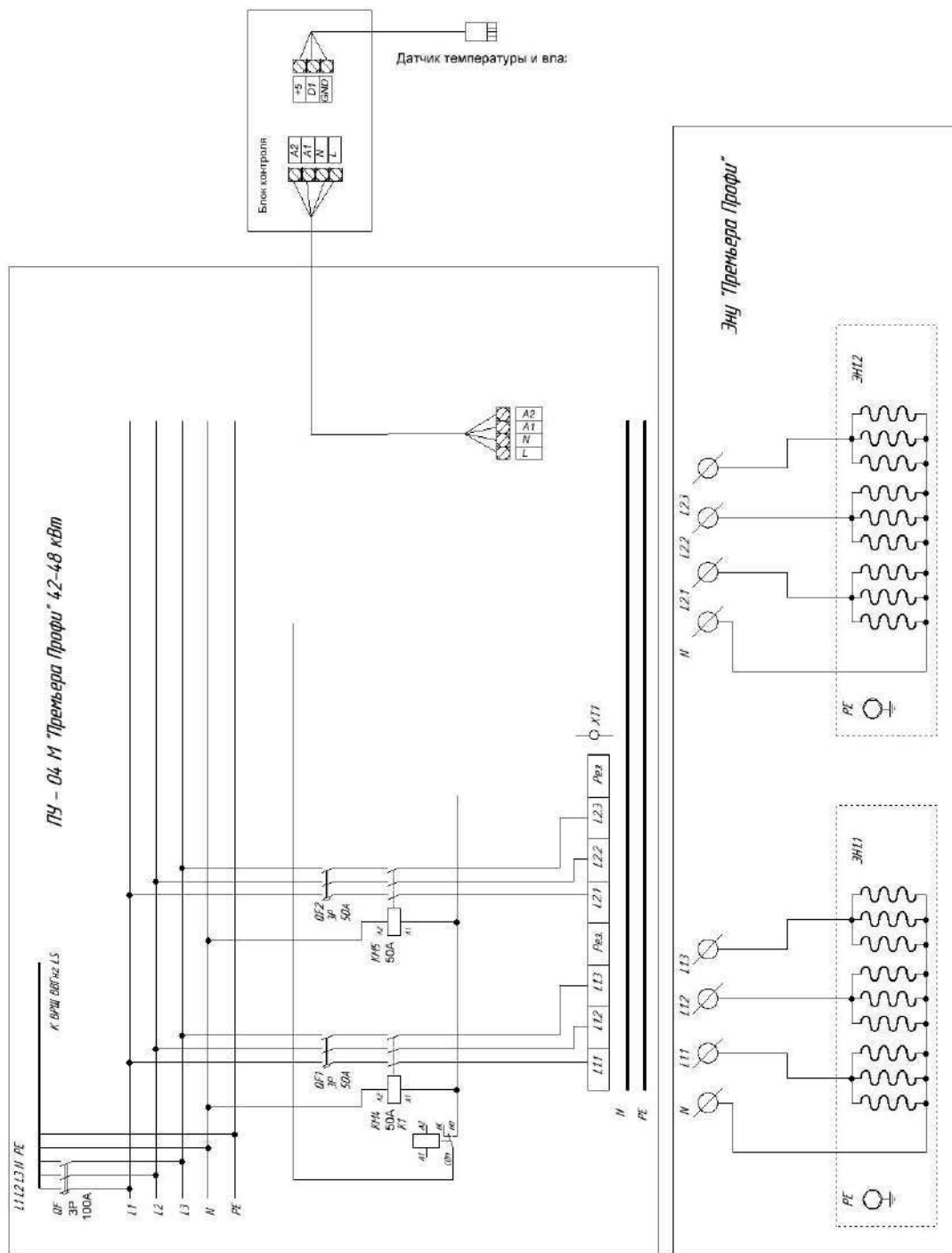

Fig. 1.3.7 Connection of the Device to the electrical network in a single-section version of 42-48 kW

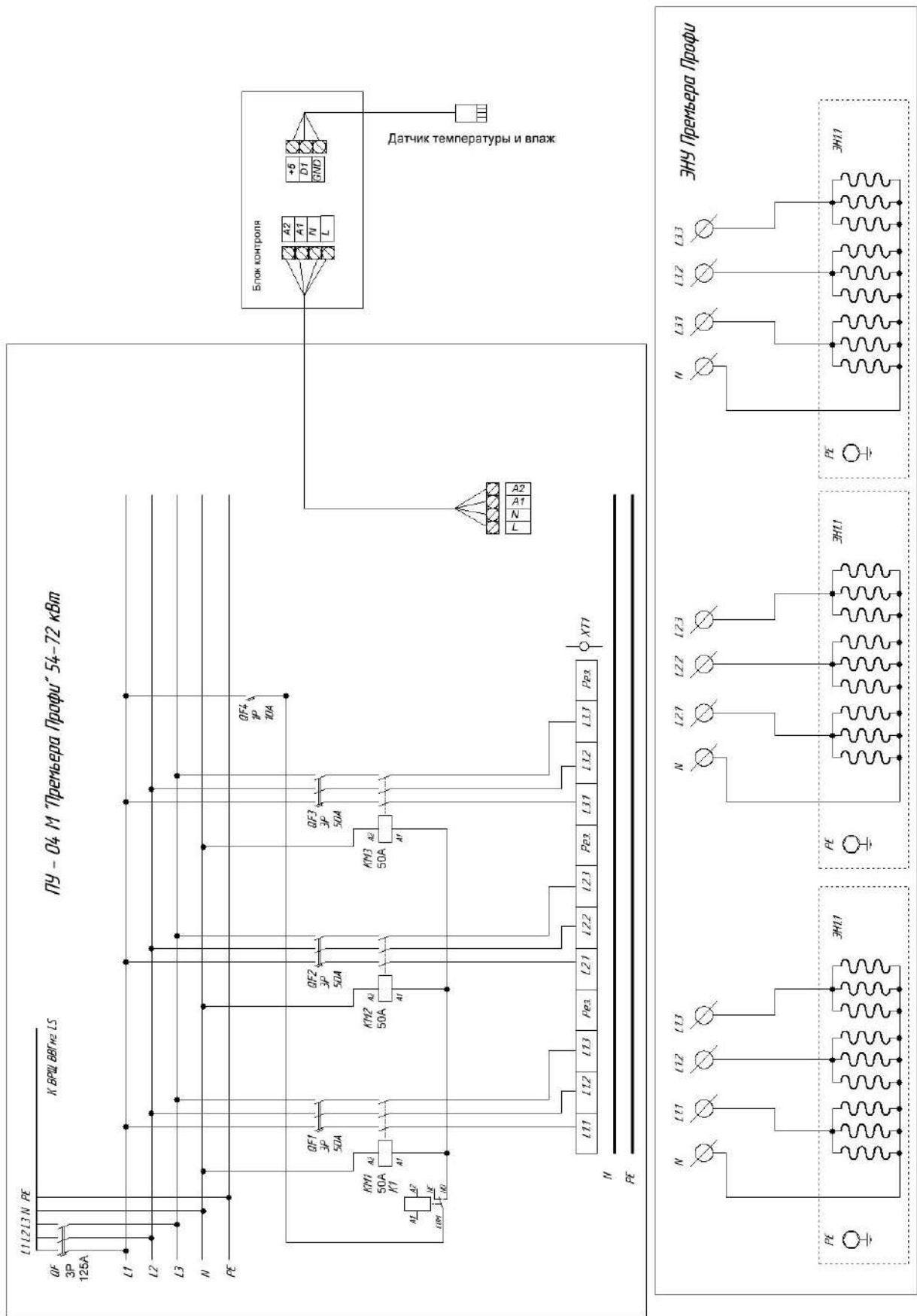

Fig. 1.3.8 Connection of the Device to the electrical network in a single-section version of 54-72 kW

1.4 Device construction and operation

Depending on the power (Table 1.2.1), the device consists of two or three tubular electric heater units (EN 1.1, EN 1.2, EN 1.3) installed in a single case. The outer body is made in the form of a prefabricated structure made of stainless steel. Tubular electric heater units are made of stainless steel sheet, tubular electric heaters (tubular electric heaters) are located on their bases. The number and capacity of tubular electric heaters in each section provide the required total capacity of the furnace according to Table 1.2.1. In the lower part of the tubular electric heater units, there are terminal blocks for connecting the electric heating device to the control panel. Each unit is connected with its own, separate cable. Tubular electric heater units are installed in the external enclosure. For the convenience of connection and operation, the tubular electric heater units are installed in the furnace independently of each other, and can be serviced separately. All work with them is carried out without dismantling the electric heating device. To prevent deformation of tubular electric heaters during operation, the tubular electric heater blocks are covered with a lattice on top, on which either stones (jade, jadeite, soapstone) or cast-iron cores are placed.

Depending on the model and power, the device is equipped with special products - stainless steel heat accumulators, in the amount of 1 to 6. The design of heat accumulators guarantees not only absolutely safe and efficient production of environmentally friendly steam, excluding the possibility of water ingress on the hot surface of tubular electric heaters, but also contributes to the exit of superheated air through the "stone plug" from the tubular electric heater space; The combination of installed heat accumulators allows you to obtain the purest steam almost continuously.

In combination with heat accumulators, and, if necessary, without them, in order to prevent the formation of a "stone plug" and the occurrence of a critically high temperature under the grate in the area of the tubular electric heaters, the device is equipped with special products - large and small air diffusers that provide free exit of superheated air from under the grille, and, in general, increase the efficiency of the device (Annex 3).

The device is controlled using a remote control panel (PU), which allows you to set and maintain the required temperature in the room, as well as limit the time of continuous operation of the device.

The control panel includes the following:

- digital temperature meter;
- thermostat with a control range from +30 to +125 C°;
- two or three (depending on the version) control loops for switching on and off the Device

The control panel provides:

- automatic complete shutdown of the Device if more than 6 hours have passed since the last exposure to the control panels (factory settings)

- automatic switching on and off of the Device in accordance with the temperature set on the control panel in the steam room;
- indication of the current temperature and humidity, delay in switching on the device up to 24 hours with an interval of 15 minutes

The control panel consists of two units: the Control Unit and the Power Unit. The Control Unit is a plastic case, on the front surface of which there is a text information screen and control buttons. Inside the Control Unit there are electronic components that provide the algorithm of the Device's operation. The electronic components of the Control Unit are mounted on a printed circuit board. The control panel is equipped with a temperature sensor installed inside the steam room. The temperature sensor (TS) and humidity sensor is connected to the control panel with its own 5 or 10 meter cable. Extension of the sensor cable over 10 m only by agreement with the manufacturer, through a signal amplifier (driver). It is not recommended that the sensor cable intersect the power lines or lay them in parallel. The length of the connecting cable between the Control Panel and the power unit of the remote control is 5 or 10 meters. The possibility of additional extension is agreed with the Manufacturer. The Power Unit is made in the form of a metal, electrical cabinet with dust and moisture protection IP 65. Inside of which there are circuit breakers, switching components, busbars and terminals for connecting cables. The design of the Power Unit allows sequentially, depending on the need, to ensure the step-by-step switching of the furnace power by separate groups of tubular electric heaters along its long side.

1.5 Control-measuring instrumentation

Temperature control in the steam room is carried out using the measuring device of the control panel.

The TS is installed at the level of the head of a sitting person on the topmost shelf in the steam room.

The distance from the TS to the ceiling should not be more than 1.5 m.

In any case, the temperature on the surfaces of unprotected flammable materials should not exceed 180 ° C.

It is forbidden to install the temperature sensor in the air supply areas and above the door.

It is forbidden to operate an electric heating device furnace with a faulty TS or without TS.

1.6 Marking and sealing

The marking is applied to the nameplate located on the body of the Device and to the nameplate located on the body of the Power Unit.

The marking meets the requirements of Article 5 of TR CU 004/2011 and contains the following data:

- symbol (type) of the Device;
- trademark or name of the manufacturer;

- serial number;
- device power in kilowatts;
- rated voltage of the supply network in volts;
- weight of the device in kilograms;
- year of manufacture;
- country of manufacture;
- designation of technical specifications;
- a single product circulation mark on the market of the Customs Union member states.

Sealing of the Device is not provided.

1.7 Packaging

The device is packaged in wooden containers.

The packaging and preservation of the device meet the requirements of Section 3 GOST 23216 for transportation, storage and shelf life.

2. PRODUCT USAGE

2.1 Preparing the room before using the product

The walls and ceiling of the steam room should have good thermal insulation. Materials that accumulate heat (tiles, plaster) should be additionally insulated. It is recommended to sheathe the steam room or sauna with wood. It should be remembered that the use of decorative heat-absorbing materials (stone, brick, tiles, etc.) as heat-accumulating elements requires additional time and electricity for their heating.

2.2 Safety measures

- in order to strictly comply with the rules of fire and electrical safety, the connection of the Device must be made by electrical personnel who have permission to work with electrical installations up to 1000 V;
- electrical wiring must be made in accordance with the standards of Electrical Installation Regulations and Technical Regulations;
- acceptance of the Device for operation must be carried out with the execution of an appropriate act;
- it is forbidden to install the Device in premises that do not meet fire safety requirements (SNiP (СП) 31-05-2003, MGSN (МГСН) 4.04-94, SP(СП) 456.1311500.2020);
- the power of the Device must correspond to the volume of the steam room;
- the vertical distance between the upper part of the Device and the horizontal overlap of the room must be at least 1.2 m;
- the area of the floor on which the Device is installed must be protected by a heat-

resistant, non-combustible, heat-insulating material (screen) with a thickness of at least 10 mm. Horizontal distance from the body of the Device to flammable surfaces must be at least 300 mm. If the Device is installed at a distance of less than 300 mm from flammable surfaces, a thermal insulation screen must be installed. The thickness of the shield must be at least 10 mm. In any case, the temperature increase on the flammable surface from the impact of the Device must not be more than 500C. Thermal insulation material for protection is not included in the delivery set of the Device and must be purchased separately;

- the ceiling above the Device must be protected by a thermal insulation shield made of non-combustible material, at least 10 mm thick (also purchased separately). The distance between the ceiling and the panel must be at least 50.0 mm. The distance between the top of the Device and the ceiling must not be less than 1.2 meters.

Note. The company manufactures thermal insulation screens equipped with super-thin basalt fiber up to 10 mm thick, of various sizes, which can be purchased additionally if necessary, in accordance with the design of the steam room.

- the room in which the Device is installed must have ventilation. The inlet and exhaust are located respectively at the bottom and top diagonally of the room;
- only one Device is allowed to be used in the room;
- the cable used to connect the Device to the control panel must be in heat-resistant insulation of the SiHF/GL-P type. Russian analogues: PVKV, RKGМ, PNBS or others. 1.2.1 of these Guidelines. The ends of the cable cores connected to the Device and the control panel must be serviced or equipped with special tips;
- it is forbidden to operate the Device without a protective circuit breaker! To connect the Device, depending on the electrical circuit, a circuit breaker should be provided with a rating corresponding to the current load consumed by the Device (see Table 1.2.1 of this Instruction Manual). Connection of other consumers to the circuit breaker is prohibited;
- it is forbidden to operate the Device without a control panel;
- the device must be securely grounded;
- before turning on the Device, it is necessary to make sure that there are no foreign objects on the Device and inside it;
- the Device shall be operated only in an upright position.

ATTENTION!!!

In order to strictly comply with the rules of fire and electrical safety, the connection of the control panel and the electric heating device must be made by electrical personnel who have access to work with electrical installations up to 1000 V and an electrical safety group of at least III. Electrical wiring must be made in accordance with the norms of the Electrical Installation Code.

2.3 Preparing the device for use

- a) open the container, check the completeness, remove protective and packaging materials;
- b) install the Device in the bath or sauna room in accordance with the Installation Instructions (see Annexes 1, 2 of this Instruction Manual);
- c) install the control panel at a height of about 1.5 meters outside the steam room, in a dry, easily accessible place for visual control and maintenance;
- d) install a temperature sensor in the bath or sauna room in the treatment area, approximately at the level of the head of the person sitting on the top shelf. The sensor may not be installed in the immediate vicinity of the Device, on or above the ceiling, front door.









2.4 Device Operation

Safety measures:

- the device belongs to electrical installations, therefore, during operation, it is necessary to comply with all the rules and regulations of the current documents on safety and fire safety of electrical installations;
- do not touch the Device when it is heated – this may cause burns;
- do not leave children unattended in the sauna;
- be careful to apply water to stones or cast iron cores. The resulting steam can cause burns;
- do not cover the Device with any objects;
- do not impede the circulation of air around the Device;
- do not use the Device if it is damaged (foreign odor, smoke, fire, etc.);
- do not use solvents as a cleaning agent to care for the Device;
- do not cover the temperature sensor with any objects;
- it is forbidden to operate the Device with a faulty control panel;
- in case of malfunction of the Device or the control panel, immediately disconnect the Device using the input protective circuit breaker. Take measures for its qualified repair.

2.5 Work procedure

- a) turn on the protective circuit breaker of the external VA network. In the Power Unit, turn on the input circuit breaker QF, circuit breakers of tubular electric heaters QF1, QF2, QF3, (as well as QF4 in the four-cable version), the QF4 control circuit breaker (QF5 in the four-cable version);

- b) turn on the Device by pressing  on the Control panel;
- c) connect the required number of tubular electric heaters by pressing buttons . Each button synchronously connects a group of tubular electric heaters in the furnace blocks. In the two-section version, two upper buttons are involved;
- d) on the control panel, set the temperature in the room with the buttons  and . A long press of the buttons provokes a quick change in the parameter. Further control of the electric furnace is carried out automatically in accordance with the set temperature. The control panel maintains the temperature in the steam room within +/- Delta (hysteresis) of the set temperature. By default, the hysteresis of the temperature setting makes +/- 2°C;
- e) the Control Panel provides a delay mode for switching on the Device in the range of up to 24 hours. To activate the power-on delay mode, press the , then, by pressing  and , set the desired power-on delay time. To exit the on-time delay mode, press the button again ;
- f) at the first technical activation of the Device, light smoke and odor may appear. In this case, turn off the Device and ventilate the room. After that, turn the Device back on.



2.6 Possible malfunctions and their elimination

External signs of malfunction	Probable cause	Methods of elimination
The device is turned on, but there is no heating.	There is no voltage in the electrical network.	Check network health.
The room temperature does not reach the set temperature	Supply voltage below rated	Take measures to normalize the supply voltage
The temperature in the steam room is not regulated	Open or short circuit in the temperature sensor circuit	Fix an open or short circuit

2.7 Operations in extreme conditions

In the event of a threat to human life or fire, regardless of the causes of their occurrence, it is necessary to do the following:

- immediately turn off the Device with the circuit breakers of the external VA network;
- evacuate people from the room where the device is located;
- call the fire service and the ambulance service;
- take measures against the spread of fire.

3. TECHNICAL MAINTENANCE

During the maintenance of the Device, the following types of work should be performed:

- cleaning of the external surface of the Device - regularly;
- inspection of stones for vaporization, their fault detection, replacement - 2 times a year;
- checking the state of the grounding circuit and the reliability of power contacts on the electric heating device and the control panel - 2 times a year;
- all cleaning and repair work of the Device and the Control Panel should be carried out only when they are disconnected from the mains;
- the device must be serviced by electrical personnel who have permission to work with electrical installations up to 1000 V.

4. STORAGE AND TRANSPORTATION

- The device must be stored in a packaged form before installation at the place of use;
- Transportation of the Device in a packaged form is carried out by any type of closed transport. When transporting, the Device must be secured in such a way as to prevent it from moving and overturning.

5. UTILIZATION

- the device must not be disposed of with household waste;
- the device should be disposed of at an appropriate recycling point for waste electrical and electronic equipment;
- For more information, please contact your local authorities or your nearest waste collection point

6. WARRANTY OBLIGATIONS

- the device fully complies with the requirements of the Technical Regulations of the Customs Union TR CU 0042011 "On the safety of low-voltage equipment" and TR CU 0202011 "Electromagnetic compatibility of technical means", TR CU 010/2011 "On the safety of machinery and equipment", TR EAEU 037/2016 "On the restriction of the use of hazardous substances in electrical engineering and radio electronics products", GOST 30345.0-95 "Safety of household and similar electrical appliances", TU 27.51.24-018-51036005-2019 and TU 27.51.24-019-51036005-2019. Certificates of Conformity NoEAEU RU C-RU. HB26. B.05198/24, NoEAEU RU C-RU. HB26. B.03040/23, Declarations of Conformity EAEU N RU D-RU.RA04.B.37952/23, EAEU N RU D-RU.RA04.B.37913/23, EAEU N RU D-RU.RA01.V.
- the manufacturer guarantees uninterrupted operation of the Device for 12 months from the date of sale, provided that the Consumer complies with the rules of this Instruction Manual;
- the warranty period is calculated from the date of purchase, if the date of purchase of the Device is confirmed by the seal and signature of the seller on the manufacturer's warranty card and the presence of original documents confirming the date of purchase (sales receipt, invoice, UTD, contract, etc.). In the absence of supporting documents on the purchase, the Warranty Period is calculated from the date of manufacture specified in the Warranty Card;

Warranty repairs are not carried out in the following cases:

- expiration of the warranty period;
- in case of independent repairs of the Device;
- in case of damage to the Device caused by the fault of the Consumer;
- in case of violation of the rules for storage and transportation of the Device;
- when using the Device with a non-certified third-party remote control

ATTENTION!!!

The Manufacturer is not responsible for the consequences resulting from violation of the rules for installation, connection and operation of the Device set forth in this manual.

Annex 1 Instructions for assembling an electric furnace

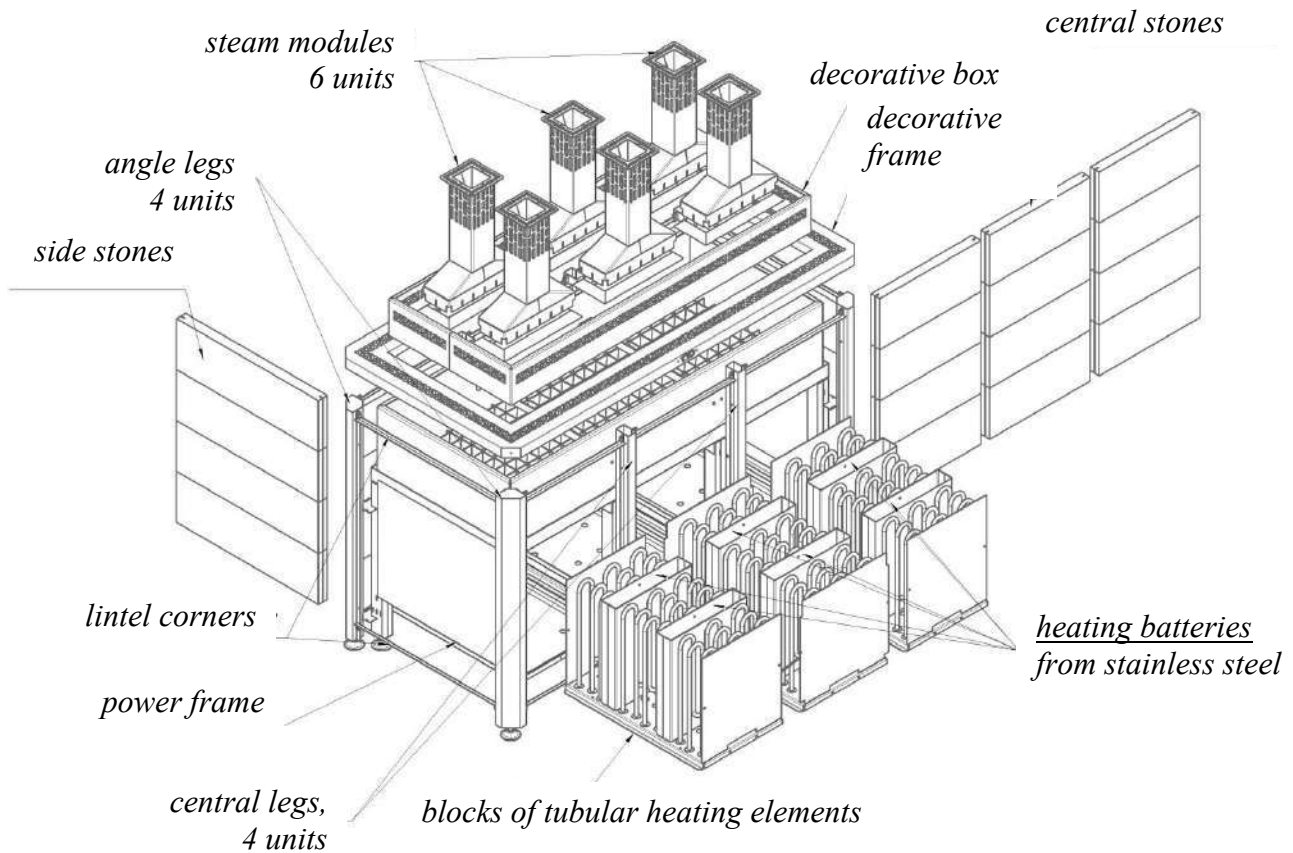

Fig. 1 Assembly in stone of the electric heating device "Premiera Profi"

1. Install the stove load-bearing frame on a flat base (Fig. 1), put the stone grate in it.
2. Remove the tubular electric heater units from the power frame to the distance required to connect the supply cables. Connect the cable from the control panel to the terminals of the Device. The terminal block for connection is installed on the tubular electric heater blocks. The device is connected to the control panel with a cable in heat-resistant insulation of the following type: RKGМ, FKGM, PRKS or similar, with a cross-section not less than specified in Table 1. 1.2.1 of this Instruction Manual.

IMPORTANT. It is necessary to strictly observe the markings applied to the terminals of the Device and the control panel (Fig. 1.3.1 – 1.3.5). After connecting the wires to the terminals of the Device, it is recommended to check the correct connection and operability of the tubular electric heaters by test switching. The design of the Device allows you to check each section separately.

Fix the bundles of wires to each unit of tubular electric heaters with a standard bracket.

3. After connecting the heating elements to the supply cable, slide the heating element unit into the workplace until the leading edge of the base of the unit aligns with the plane of the support legs. At the same time, align the axes of the places where the heat accumulators are installed with the holes for the funnel in the grate and with the holes in the base of the block for the overflow tubes of the heat accumulators.

4. Install heat accumulators*. For installation, remove the grille from the power frame, place the heat accumulator units in the standard places between the tubular electric heaters (it is possible to install one or two heat accumulators in each section), placing the overflow tubes in special holes in the base of the blocks. Lay the grille back into the load-bearing frame, orienting the holes for the funnels symmetrically in the center of the heat accumulators.

5. Install the central cladding legs by screwing them to the furnace load-bearing frame.

6. Install the lower and upper angles-bridges on the central legs on bolted connections, but do not tighten

7. Install the corner legs, connect them to each other and the central legs using the bridge angles in the lower and upper parts with bolted connections, but do not tighten. Align the horizontal level of the support legs of the load-bearing frame and the cladding structure with screw support legs.

8. Alternately removing the upper lintel corners and tightening the lower lintel corners in the desired position, install the elements of the stone cladding and fix them with the upper lintel corners.

9. After assembling the exterior stone cladding, install the upper decorative frame on the load-bearing frame.

10. Install the decorative box in the decorative frame.

11. Install the steam modules of the heat accumulators in the grooves of the grate*.

12. Install the air diffusers (see Annex 3)*

13. Fill the Device with stones (or kernels) for vaporization by placing them on a grate above the tubular electric heaters.

The stones used for laying in an electric heating device must meet the requirements listed below:

- the stones must withstand high temperatures and temperature changes caused by the evaporation of water from the surface of the stones. The use of jade, jadeite, soapstone stones is recommended;
- before use, stones should be thoroughly rinsed to avoid odor and dust;
- in order to avoid the formation of a "stone plug", overheating of tubular electric heaters and shortening their service life, stones should be laid freely, ensuring effective air circulation between them;
- the recommended weight and size of the stone (core) is specified in paragraph 1.2.1 of this Instruction Manual;

— It is forbidden to use soluble salt blocks in stone filling.

ATTENTION! Do not use stones of unknown origin! They may contain sulfur compounds and radionuclides, which make them unsuitable and even dangerous for use in the bath.

14. 14. The device is ready to use.

* - In case of acquisition.

In the case of a two-section version of the Device, the assembly procedure is similar to that described above.

For the convenience of connection and operation, the tubular electric heater units are installed in the furnace independently of each other and can be serviced separately. All work with them is carried out without dismantling the ENU. To remove one of the sections from the electric heating device for inspection or repair of tubular electric heaters installed on it, it is necessary to dismantle the decorative frame in the reverse order of installation, and remove one of the elements of the central stone cladding immediately in front of the section. The design of the units allows you to remove and install the units from any side of the Device, convenient for the Consumer.

Annex 2

Instructions for assembling an electric stove in the "Himalayan salt" version

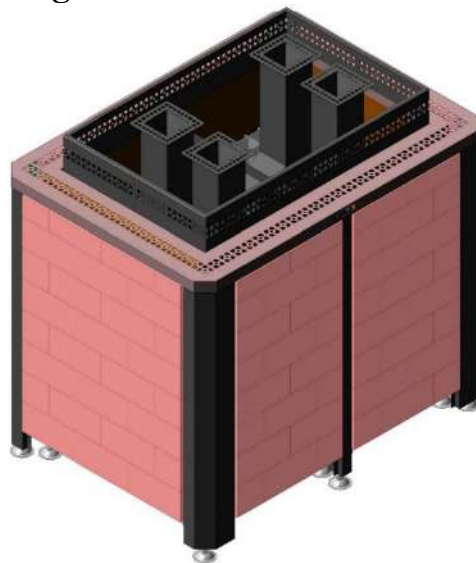

Fig. 2 Assembly of the electric heating device "Premiera Profi" "Himalayan salt"

1. Install the stove load-bearing frame on a flat base (Fig. 2)
2. Remove the tubular electric heater units from the power frame to the distance required to connect the supply cables. Connect the cable from the control panel to the terminals of the Device. The terminal block for connection is installed on the tubular electric heater blocks. The device is connected to the cable control panel with heat-resistant insulation of the following type: RKGM, FKGM, PRKS or similar, with a cross-section not less than specified in Table 1. 1.2.1 of this Instruction Manual.

IMPORTANTLY. It is necessary to strictly observe the markings applied to the terminals of the Device and the control panel (Fig. 1.3.1 – 1.3.5). After connecting the wires to the terminals of the Device, it is recommended to check the correct connection and operability of the tubular electric heaters by test switching. The design of the Device allows you to check each section separately.

Fix the bundles of wires to each block of tubular electric heaters with a standard bracket.

3. After connecting the heating elements to the supply cable, slide the heating element unit into the workplace until the leading edge of the base of the unit aligns with the plane of the support legs. At the same time, align the axes of the heat accumulators with the holes for funnels in the grate and with the holes in the base of the blocks for the overflow tubes of the heat accumulators.

4. Install heat accumulators*. For installation, remove the grille from the power frame, place the heat accumulator units in the standard places between the tubular electric heaters (it is possible to install one or two heat accumulators in each section), placing the overflow tubes in special holes in the base of the blocks. Lay the grille back into the load-bearing frame, orienting the holes for the funnels symmetrically in the center of the heat accumulators.

5. Install the central cladding legs by screwing them to the furnace load-bearing frame.

6. Install the lower corners on the bolted joints on the central legs.

7. Install the corner legs, connect them to each other and the central legs using the bridge angles in the lower and upper parts with bolted connections, but do not tighten.

8. Alternately removing the upper corners-lintels, install the elements of the salt lining (salt blocks). Salt blocks are laid starting from the bottom row. Grooves are cut along the perimeter of the blocks to fix the cladding elements. Lay the lower row of blocks on the lintel corners in such a way that the lintel corners, central and side legs fall into the grooves in the lower and side parts of the blocks. Insert a fixing bar (supplied) into the grooves in the upper part of the blocks. Lay the next row of blocks on the plank in the order described above. When installing, large and small blocks should be alternated in a checkerboard pattern (Fig. 9). After assembling the upper row of cladding, tighten the lower lintel corners and fix the cladding with the upper lintel corners. The dimensions of the salt blocks for the central and side parts of the cladding differ from each other, so it is important to use only the blocks intended for this part of the cladding. The purpose of the blocks is indicated on the packaging of salt blocks.

9. After assembling the exterior cladding, install the upper decorative frame on the load-bearing frame.

10. Install the decorative box in the decorative frame.

11. Install the steam modules of the heat accumulators in the grooves of the grate.

12. Install the air diffusers (see Annex 3)*

13. Fill the Device with stones (or kernels) for vaporization by placing them on a grate above the tubular electric heaters.

Stones used for laying in an electric heating device must meet the requirements listed below:

- the stones must withstand high temperatures and temperature changes caused by the evaporation of water from the surface of the stones. The use of jade, jadeite, soapstone stones is recommended;
- before use, stones should be thoroughly rinsed to avoid odor and dust;
- in order to avoid the formation of a "stone plug", overheating of tubular electric heaters and shortening their service life, stones should be laid freely, ensuring effective air circulation between them;
- the recommended weight and size of the stone (core) is specified in paragraph 1.2.1 of this Instruction Manual;

It is forbidden to use soluble salt blocks in stone filling.

ATTENTION! Do not use stones of unknown origin! They may contain sulfur compounds and radio nuclides, which make them unsuitable and even dangerous for use in the bath.

14. The device is ready to use.

* - In case of acquisition.

In the case of a two-section version of the Device, the assembly procedure is similar to that described above.

For the convenience of connection and operation, the tubular electric heater units are installed in the furnace independently of each other and can be serviced separately. All work with them is carried out without dismantling the electric heating device. To remove one of the sections from the electric heating device for inspection or repair of tubular electric heaters installed on it, it is necessary to dismantle the decorative frame in the reverse order of installation, and remove the elements of the central lining immediately before the section. The design of the units allows you to remove and install the units from any side of the Device, convenient for the Consumer.

Annex 3

Air Diffuser Installation Instructions

Before filling the Device with stones (cores), in order to prevent the formation of a "stone plug" and the occurrence of a critically high temperature under the grate in the area of installation of tubular electric heaters, causing the failure of the Device, it is necessary to install air diffusers (large and small), hereinafter referred to as the air diffuser. An air diffuser is a stainless steel structure that is installed on the grate of the stone (core) compartment before it is filled with stones (cores). The air diffuser is installed on the grille from above, for installation it is necessary to align the grooves cut in the lower part with the cells of the compartment grate for filling with stones (Fig. 3, 3.1). In each section, it is possible to install up to two large air diffusers or up

to 6 pieces of small air diffusers In the case of purchasing heat accumulators, the number of air diffusers per section is reduced in proportion to the number of heat accumulators installed in the section.

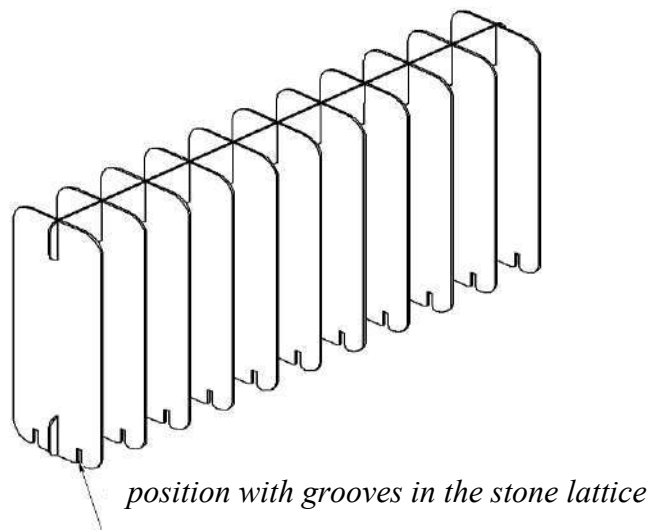

Fig. 3.1 Large Air Diffuser

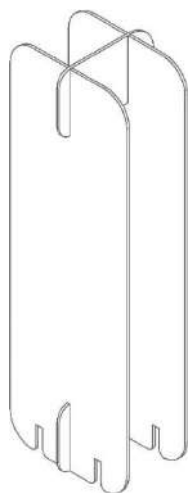

Fig. 3.2 Small Air Diffuser

Diagrams of possible maximum configurations of stoves

- Ж/А – Heat battery
- П/Ш - Steam shungite (phytosteamer)
- д/м– Small diffuser
- д/б – Large diffuser

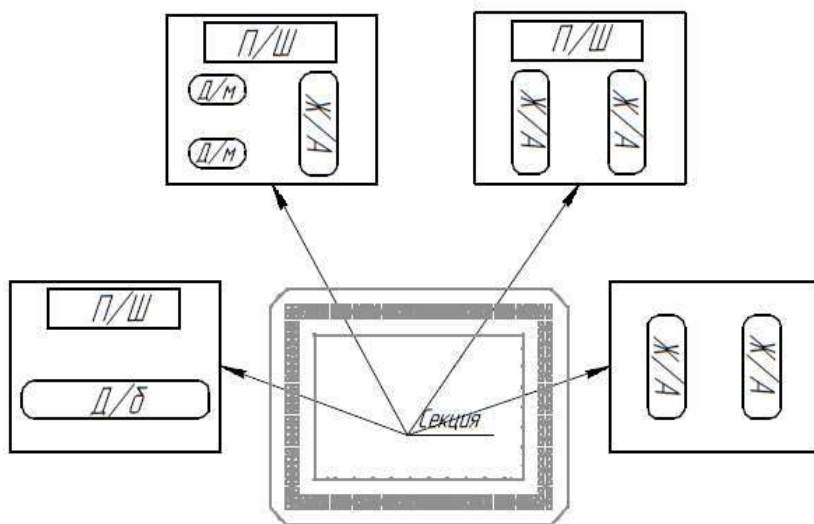

Figure 1. "Premiera Profi" in 1-sectional version

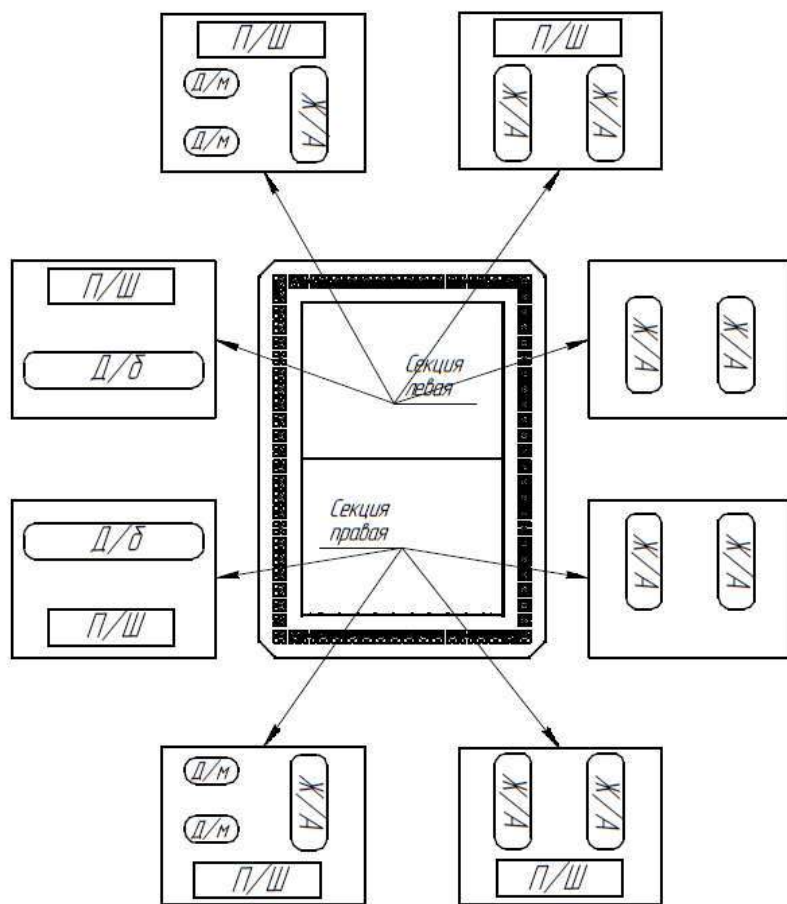

Figure 1. "Premiera Profi" in 2-sectional version

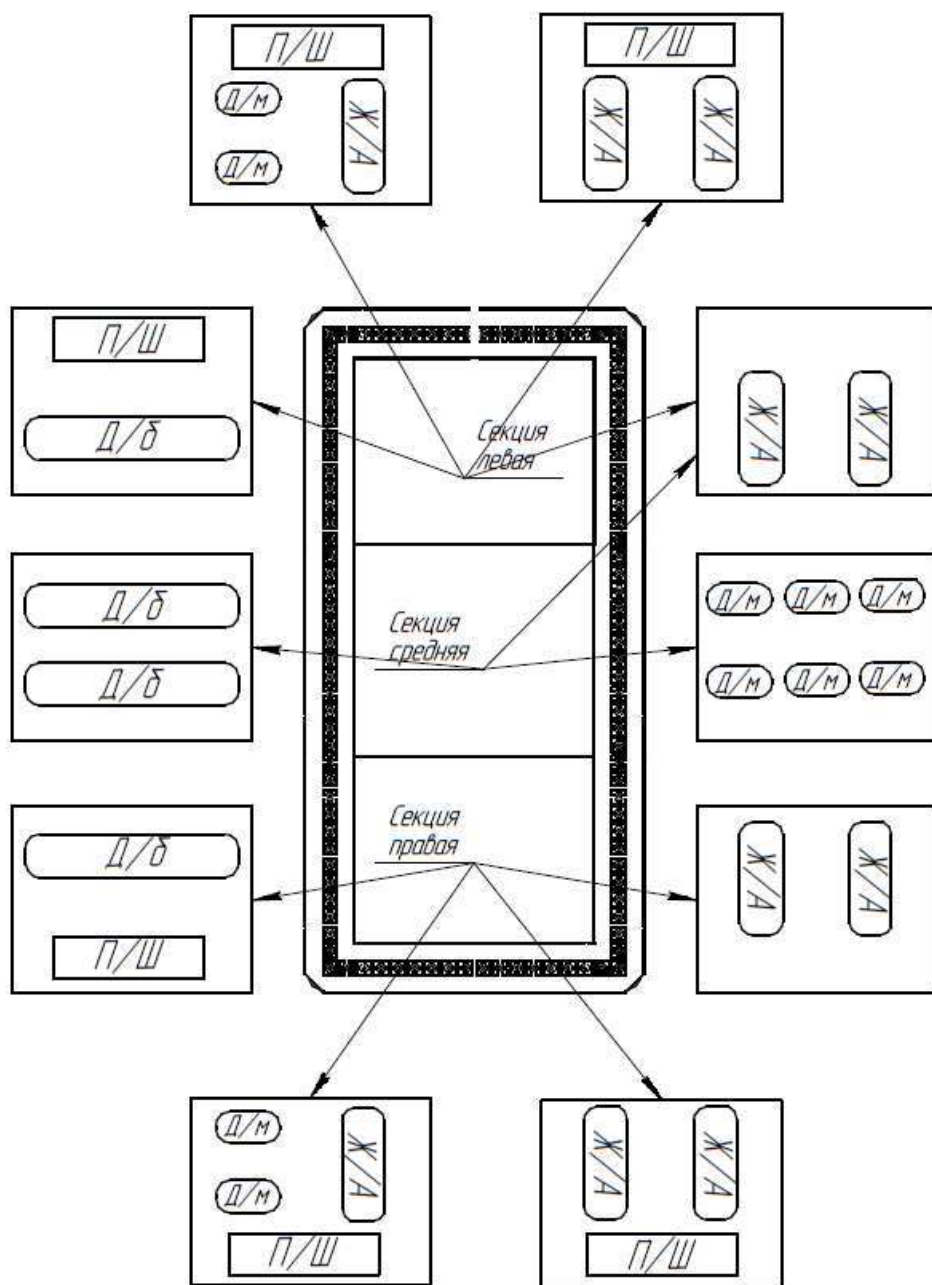

Figure 1. "Premiera Profi" in 2-sectional version

8. WARRANTY CARD

Mark of compliance of "Premiera-Profi" electric heating device with the requirements of TU 27.51.24-018-51036005-2019; TU 27.51.24-019-51036005-2019.

Date of manufacture _____

Furnace serial number _____

Remote controller serial number _____

Quality control mark _____

Stamp, address and telephone

Selling company _____

Date of sale: _____

Warranty service is carried out at the address:

142180 Russia, Moscow region,
Podolsk city, Klimovsk microdistrict, Fabrichny proezd, 4E
Multi-channel telephone: +7 495 411-99-08.
e-mail: sales@vvd.su
<http://www.vvd.su>

